

(*) Disponibile anche con albero uscita $\varnothing 16 j6$

(*) Even available with 16 mm shaft

(*) Verfügbar auch mit 16 mm welle

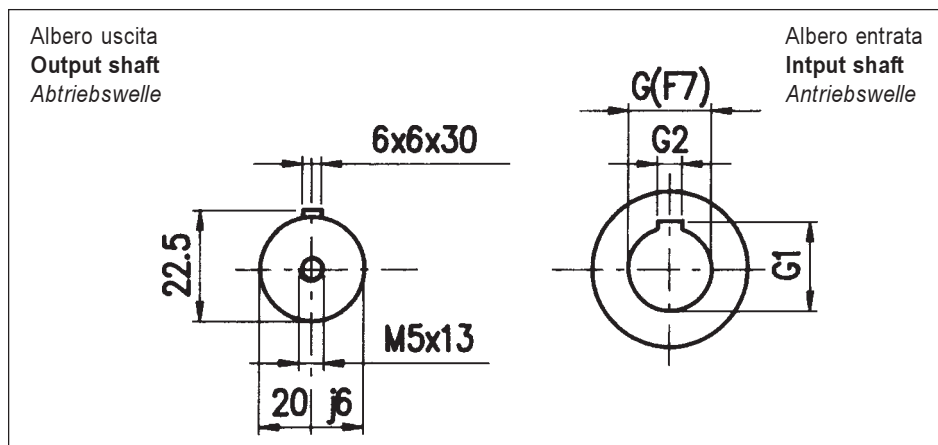

20/2	G	G1	G2	F	F1	F2	F3	F4	H
/2...56 B5 /2F...56 B5	9	10,4	3	120	100	80	8	7	208
/2...63 B5 /2F...63 B5	11	12,5	4	140	115	95	12	9	207
/2...71 B5 /2F...71 B5	14	16	5	160	130	110	10,5	9	206
/2...80 B5 /2F...80 B5	19	21,5	6	200	165	130	10,5	11	206

P = 120							
N	C	M	P	α	S	S1	U
80	44	100	120	90°	7	3	7