

PD 63/3

MPD 60/3

n_1	i	n_2	M_2	kW_1	HP_1	RD
2800	29.25	96	252	2.7	3.7	0.92
	37.68	74	270	2.3	3.1	0.92
	41.43	68	252	1.9	2.6	0.92
	47.53	59	180	1.2	1.6	0.92
	51.66	54	198	1.2	1.7	0.92
	58.72	48	270	1.5	2.0	0.92
	64.55	43	252	1.2	1.7	0.92
	67.37	42	198	0.9	1.3	0.92
	80.5	35	198	0.8	1.1	0.92
	83.22	34	270	1.0	1.4	0.92
	91.49	31	252	0.9	1.2	0.92
	114.09	25	198	0.6	0.8	0.92

n_1	i	n_2	M_2	kW_1	HP_1	RD	sf	PAM
2800	29.25	96	138	1.50	2	0.92	1.83	19/200 - 14/160
	37.68	74	177	1.50	2	0.92	1.52	19/200 - 14/160
	41.43	66	195	1.50	2	0.92	1.29	19/200 - 14/160
	47.53	59	112	0.75	1	0.92	1.61	14/160
	51.66	54	178	1.10	1.5	0.92	1.11	19/200 - 14/160
	58.72	48	138	0.75	1	0.92	1.95	14/160
	64.55	43	152	0.75	1	0.92	1.66	14/160
	67.37	42	53	0.25	0.34	0.92	3.75	11/140
	80.5	35	189	0.75	1	0.92	1.05	14/160
	83.22	34	65	0.25	0.34	0.92	4.14	11/140
	91.49	31	72	0.25	0.34	0.92	3.51	11/140
	114.09	25	89	0.25	0.34	0.92	2.21	11/140

n_1	i	n_2	M_2	kW_1	HP_1	RD
1400	29.25	48	280	1.5	2.1	0.92
	37.68	37	300	1.3	1.7	0.92
	41.43	34	280	1.1	1.5	0.92
	47.53	29	200	0.7	0.9	0.92
	51.66	27	220	0.7	0.9	0.92
	58.72	24	300	0.8	1.1	0.92
	64.55	22	280	0.7	0.9	0.92
	67.37	21	220	0.5	0.7	0.92
	80.5	17	220	0.4	0.6	0.92
	83.22	17	300	0.6	0.8	0.92
	91.49	15	280	0.5	0.7	0.92
	114.09	12	220	0.3	0.4	0.92

n_1	i	n_2	M_2	kW_1	HP_1	RD	sf	PAM
1400	29.25	48	138	0.75	1	0.92	2.03	19/200 - 14/160
	37.68	37	177	0.75	1	0.92	1.69	19/200 - 14/160
	41.43	34	195	0.75	1	0.92	1.44	19/200 - 14/160
	47.53	29	110	0.37	0.5	0.92	1.81	14/160
	51.66	27	243	0.75	1	0.92	0.90	19/200 - 14/160
	58.72	24	136	0.37	0.5	0.92	2.20	14/160
	64.55	22	150	0.37	0.5	0.92	1.87	14/160
	67.37	21	76	0.18	0.25	0.92	2.89	11/140
	80.5	17	187	0.37	0.50	0.92	1.18	14/160
	83.22	17	94	0.18	0.25	0.92	3.19	11/140
	91.49	15	103	0.18	0.25	0.92	2.71	11/140
	114.09	12	129	0.18	0.25	0.92	1.71	11/140

n_1	i	n_2	M_2	kW_1	HP_1	RD
900	29.25	31	308	1.1	1.5	0.92
	37.68	24	330	0.9	1.2	0.92
	41.43	22	308	0.8	1.0	0.92
	47.53	19	220	0.5	0.6	0.92
	51.66	17	242	0.5	0.7	0.92
	58.72	15	330	0.6	0.8	0.92
	64.55	14	308	0.5	0.7	0.92
	67.37	13	242	0.4	0.5	0.92
	80.5	11	242	0.3	0.4	0.92
	83.22	11	330	0.4	0.6	0.92
	91.49	10	308	0.3	0.5	0.92
	114.09	8	242	0.2	0.3	0.92

n_1	i	n_2	M_2	kW_1	HP_1	RD	sf	PAM
900	29.25	31	157	0.55	0.75	0.92	1.96	19/200 - 14/160
	37.68	24	202	0.55	0.75	0.92	1.63	19/200 - 14/160
	41.43	22	222	0.55	0.75	0.92	1.38	19/200 - 14/160
	47.53	19	216	0.25	0.34	0.92	1.90	14/160
	51.66	17	277	0.55	0.75	0.92	0.87	19/200 - 14/160
	58.72	15	143	0.25	0.34	0.92	2.30	14/160
	64.55	14	158	0.25	0.34	0.92	1.96	14/160
	67.37	13	79	0.12	0.16	0.92	3.07	11/140
	80.5	11	196	0.25	0.34	0.92	1.23	14/160
	83.22	11	97	0.12	0.16	0.92	3.8	11/140
	91.49	10	107	0.12	0.16	0.92	2.87	11/140
	114.09	8	134	0.12	0.16	0.92	1.81	11/140

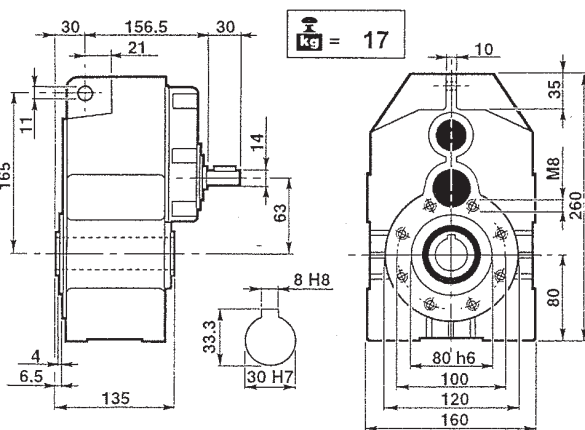

PD 63/3

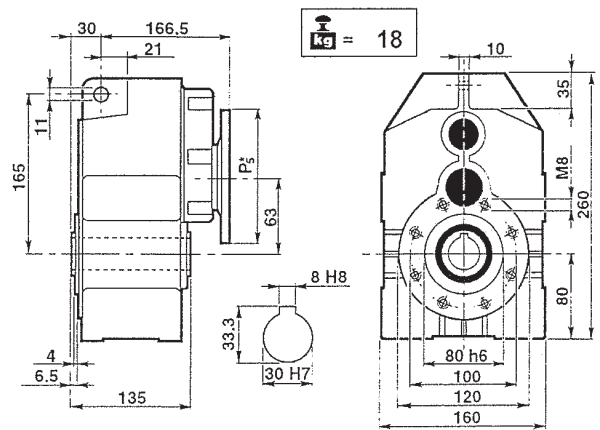

MPD 63/3

P₅*: Vedere i PAM per ogni singola versione
P₅*: See PAM size for each single version
P₅*: Siehe PAM Größe für jede Ausführung

P₅*: Voir les PAM pour chaque version simple
P₅*: Consulte los PAM de cada versión por separado
P₅*: Ver os PAM para cada versão