

DIMENSIONI	IT	DIMENSIONS	EN	ABMESSUNGEN	DE
DIMENSIONS	FR	DIMENSIONES	ES	DIMENSÕES	PT
SUPPORTI USCITA NRG 250	IT	OUTPUT BEARING ASSEMBLIES NRG 250	EN	ABTRIEBSLAGER NRG 250	DE
SUPPORTS SORTIE NRG 250	FR	SOPORTES SALIDA NRG 250	ES	SUPORTE DE SAIDA NRG 250	PT

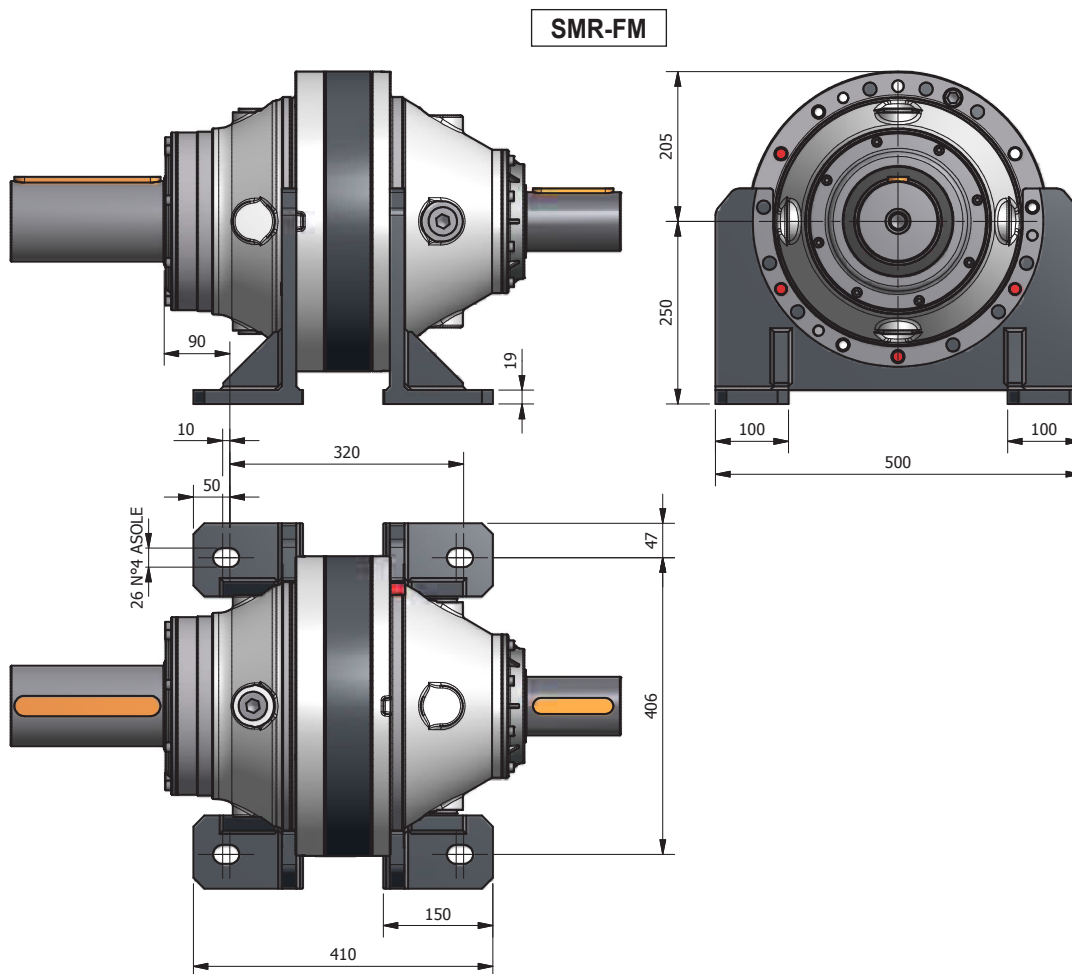

M16 12.9

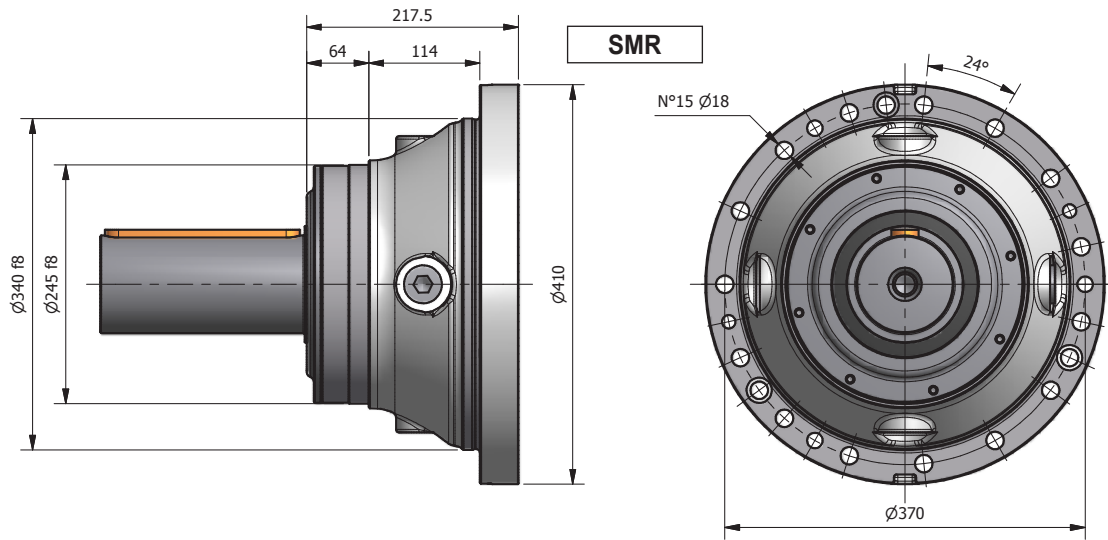

357 Nm

ALBERI USCITA NRG 250

IT

OUTPUT SHAFTS NRG 250

EN

ABTRIEBSWELLEN NRG 250

DE

ARBRES SORTIE NRG 250

FR

EJES SALIDA NRG 250

ES

EIXOS SAÍDA NRG 250

PT

CI

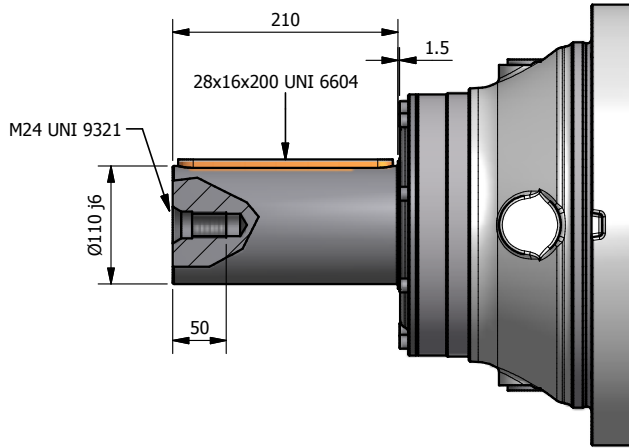

MS

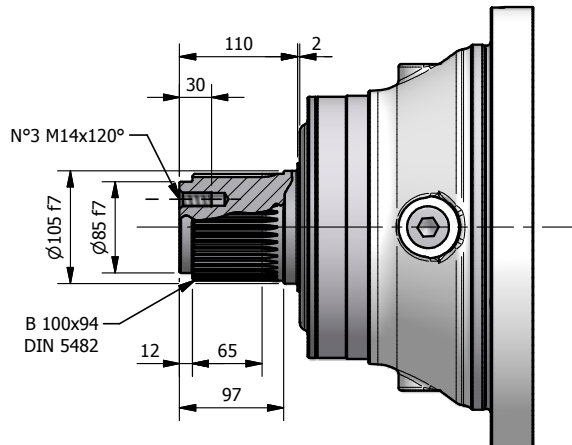

HS

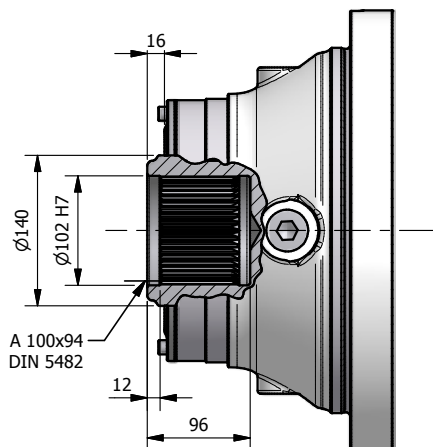

SD

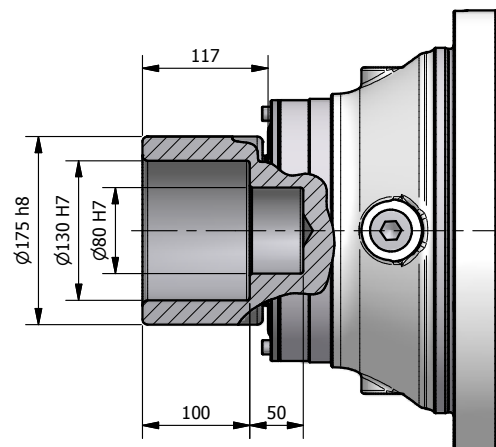

CORPI NRG 250 L	IT	NRG 250 L HOUSINGS	EN	GEHÄUSE NRG 250 L	DE
CORPS NRG 250 L	FR	CUERPOS NRG 250 L	ES	CORPO NRG 250 L	PT

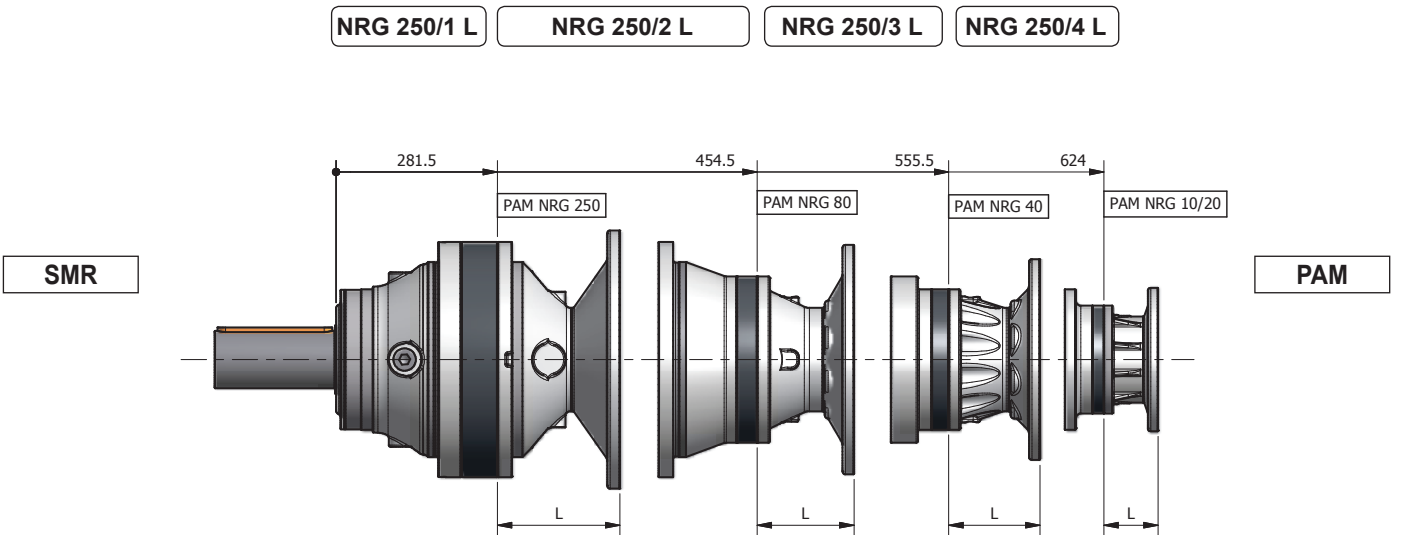
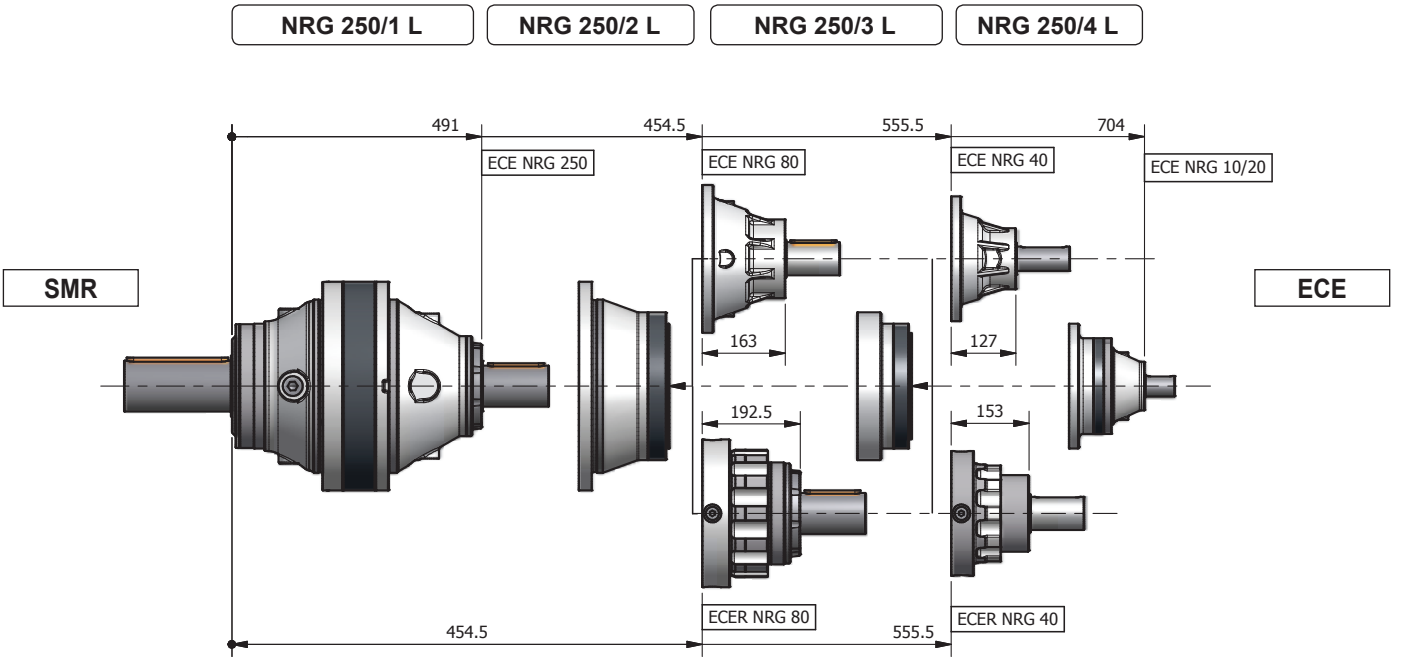

CORPI NRG 250 R - V

IT

NRG 250 R - V HOUSINGS

EN

GEHÄUSE NRG 250 R - V

DE

CORPS NRG 250 R - V

FR

CUERPOS NRG 250 R - V

ES

CORPO NRG 250 R - V

PT

NRG 250/3 R

NRG 250/4 R

SMR

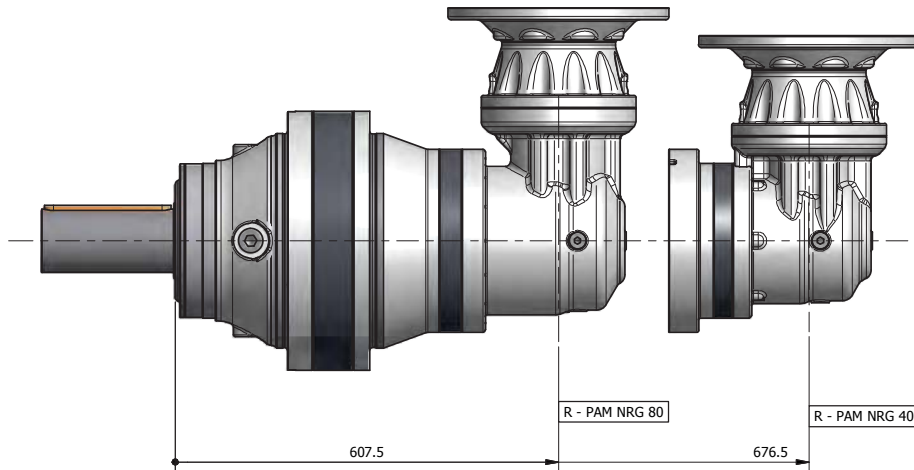

R-PAM

NRG 250/3 V

NRG 250/4 V

SMR

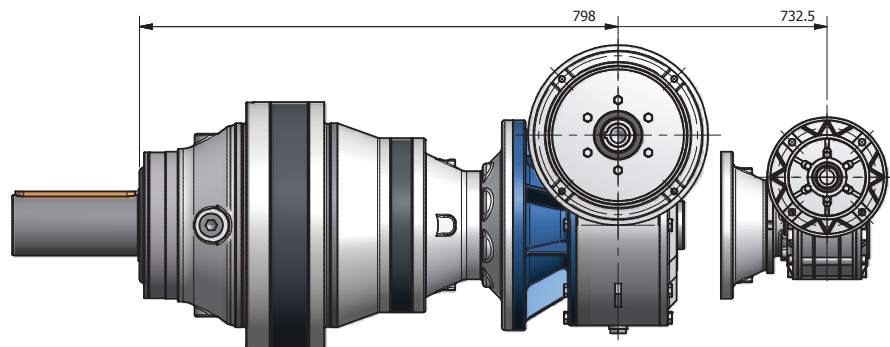

V-PAM

SUPPORTI ENTRATA NRG 250	IT	INPUT BEARING ASSEMBLIES NRG 250	EN	ANTRIEBSLAGER NRG 250	DE
SUPPORTS ENTRE'E NRG 250	FR	SOPORTES ENTRADA NRG 250	ES	SUPOORTE DE ENTRADA NRG 250	PT

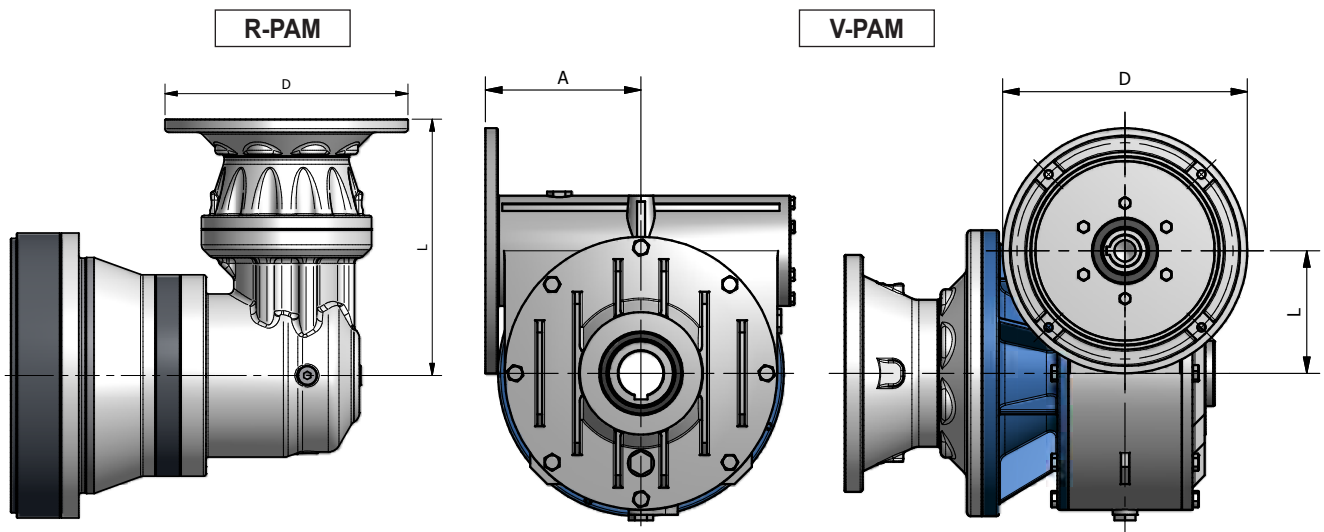
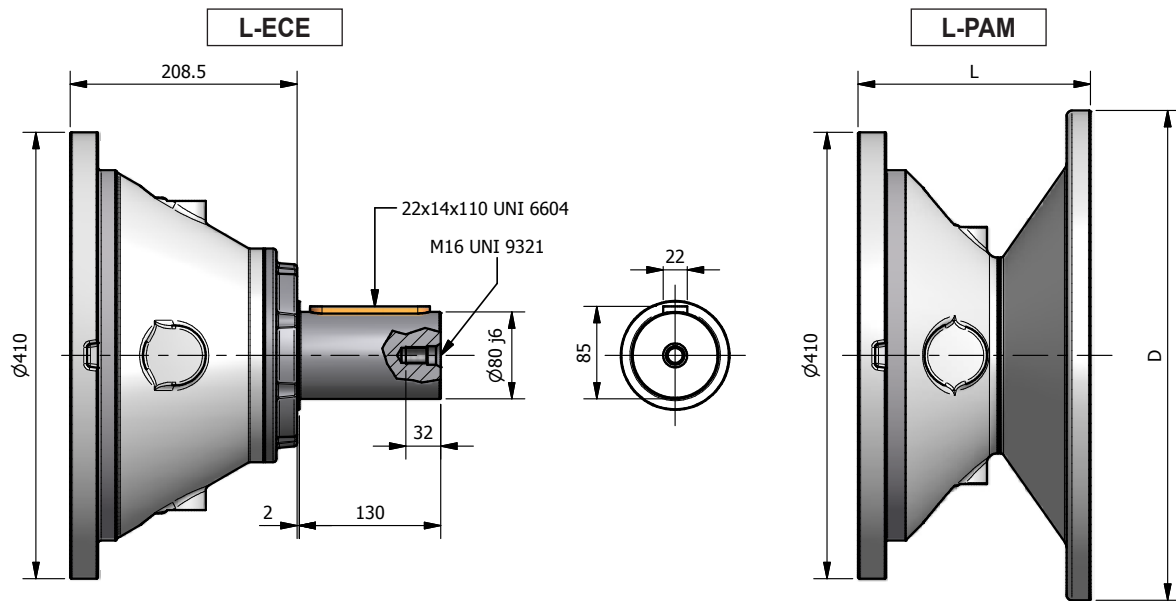

	L-PAM																					
	PAM 63		PAM 71		PAM 80		PAM 90		PAM 100		PAM 112		PAM 132		PAM 160		PAM 180		PAM 200		PAM 225	
	L	D	L	D	L	D	L	D	L	D	L	D	L	D	L	D	L	D	L	D	L	D
NRG 250/1 L	-	-	-	-	-	-	-	-	-	-	-	-	-	-	183,5	350	183,5	350	183,5	400	213,5	450
NRG 250/2 L	-	-	-	-	-	-	-	-	-	-	-	-	-	-	168,8	350	168,8	350	168,8	400	198,8	450
NRG 250/3 L	93	140	77	160	97	200	97	200	103	250	103	250	124	300	159	350	159	350	159	400	189	450
NRG 250/4 L	84,5	140	68,5	160	88,5	200	88,5	200	94,5	250	94,5	250	115,5	300	142,5	350						

	R-PAM																					
	L	D	L	D	L	D	L	D	L	D	L	D	L	D	L	D	L	D	L	D		
NRG 250/3 R	303,3	140	287,3	160	307,3	200	307,3	200	313,3	250	313,3	250	334,3	300	369,3	350	369,3	350	369,3	400	399,3	450
NRG 250/4 R	258,8	140	242,8	160	262,8	200	262,8	200	268,8	250	268,8	250	289,8	300	316,8	350						

		V-PAM																							
		PAM 63			PAM 71			PAM 80			PAM 90			PAM 100			PAM 112			PAM 132			PAM 160		
		A	L	D	A	L	D	A	L	D	A	L	D	A	L	D	A	L	D	A	L	D	A	L	D
NRG 250/3 V	B5	-	-	-	-	-	-	-	-	-	-	-	193	150	250	193	150	250	192,5	150	300	202	150	350	
NRG 250/4 V	B5	-	-	-	-	-	-	109	80	200	109	80	200	112	80	250	112	80	250						
	B14	-	-	-	-	-	-	109,5	80	120	109,5	80	140	118	80	140	118	80	250						

ACCESSORI NRG 250

IT

ACCESSORIES NRG 250

EN

ZUBEHÖR NRG 250

DE

ACCESSOIRES NRG 250

FR

ACCESORIOS NRG 250

ES

ACESSÓRIOS NRG 250

PT

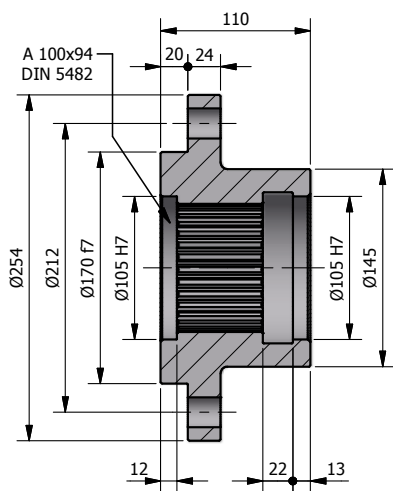

FS

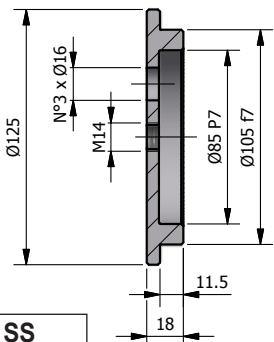
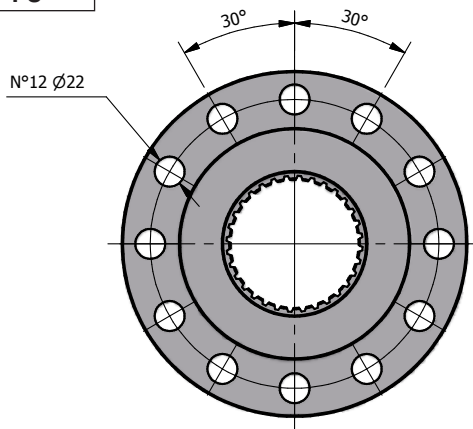

RF

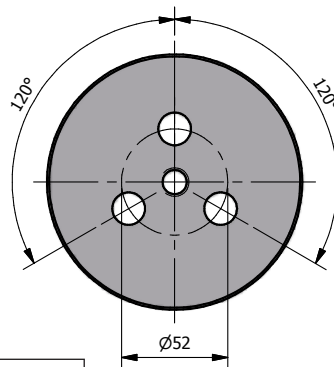

SS

BS

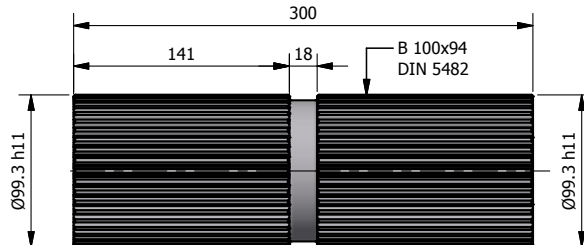
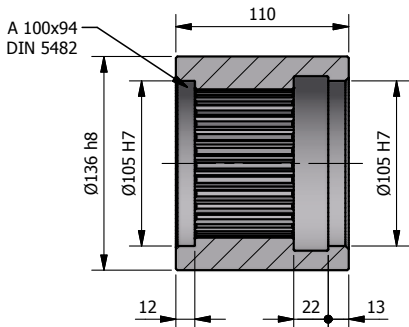

BR

BR-D

GA

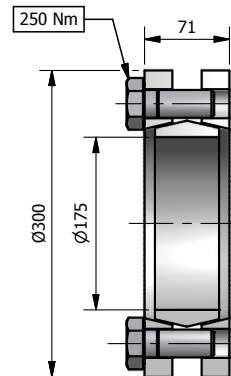
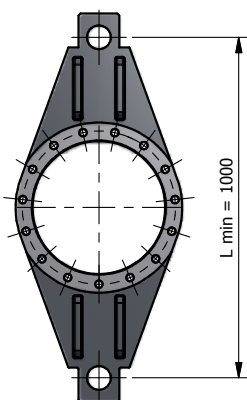
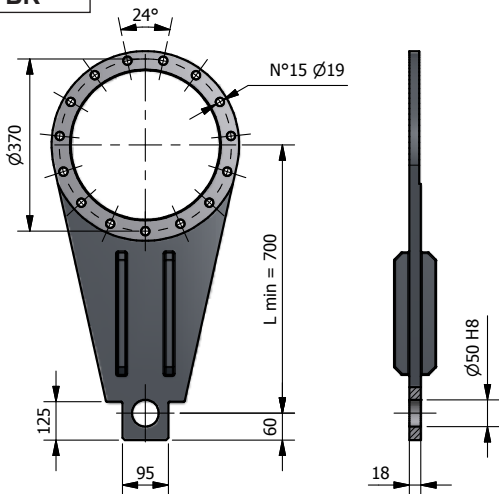

Coppia max. 41 kNm
 Max. torque 41 kNm
 Max. Drehmoment 41 kNm
 Couple maxi 41 kNm
 Par máximo 41 kNm
 Torque max. 41 kNm