

5.8 Esecuzione con vite bisporgente

5.8 Double extended worm shaft design

5.8 Versionen mit Doppelseitig Herausragender Schneckenwelle

SeA1

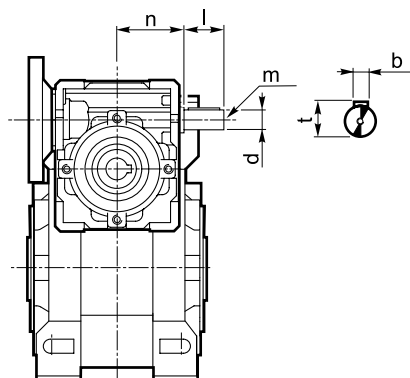

SeA2

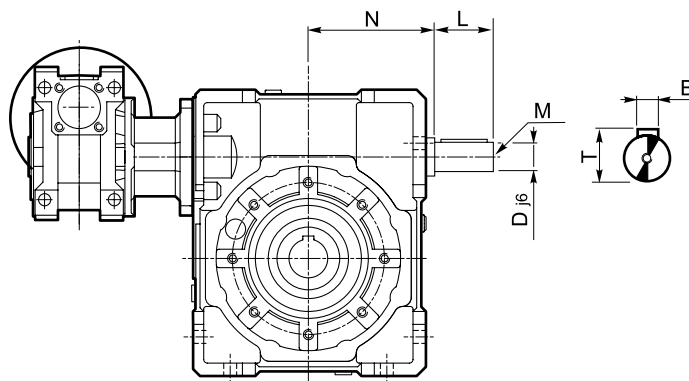

L'entrata supplementare del riduttore in uscita (SeA2) non può essere utilizzata come comando in quanto il relativo movimento risulta impedito dalla irreversibilità del primo riduttore. Utilizzato come asse condotto, avrà velocità corrispondente a quella di ingresso ridotta del rapporto del primo riduttore.

The second input shaft of the output gearbox (SeA2) can not be utilized as a drive because its motion will be stopped by the reversibility of the first gearbox. If utilized as a drive shaft its speed will be equal to the input speed decreased by the ratio of the first gearbox.

Die verlängerte Schneckenwelle des zweiten Getriebes (SeA2) kann nicht als Antrieb verwendet werden, da die Selbsthemmung des ersten Getriebes entgegengewirkt. Wird sie als Abtriebswelle verwendet, besitzt sie eine um die Untersetzung des ersten Getriebes entsprechend reduzierte Drehzahl und Drehmoment.

KXC - XXC XXF - XXA KKC	SeA1							SeA2						
	b	d j6	l	m	n		t	B	D j6	L	M	N		T
					KK-KX	XX						KK	KX-XX	
30/30	3	9	15	M4x10	42.5	42.5	10.2	3	9	15	M4x10	42.5	42.5	10.2
30/40	3	9	15	M4x10	42.5	42.5	10.2	4	11	20	M4x12	52.5	52.5	12.5
30/50	3	9	15	M4x10	42.5	42.5	10.2	5	14	25	M5x13	62.5	62.5	16
30/63	3	9	15	M4x10	42.5	42.5	10.2	6	19	30	M8x20	72.5	74.5	21.5
40/63	4	11	20	M4x12	52.5	52.5	12.5	6	19	30	M8x20	72.5	74.5	21.5
40/75	4	11	20	M4x12	52.5	52.5	12.5	8	24	40	M8x20	89	91	27
50/75	5	14	25	M5x13	62.5	62.5	16	8	24	40	M8x20	89	91	27
40/90	4	11	20	M4x12	52.5	52.5	12.5	8	24	40	M8x20	108	108	27
50/90	5	14	25	M5x13	62.5	62.5	16	8	24	40	M8x20	108	108	27
50/110	5	14	25	M5x13	62.5	62.5	16	8	28	50	M8x20	132	132	31
63/110	6	19	30	M8x20	72.5	74.5	21.5	8	28	50	M8x20	132	132	31
63/130	6	19	30	M8x20	72.5	74.5	21.5	10	38	70	M10x25	152	152	41