

Albero entrata
Input shaft
Antriebswelle

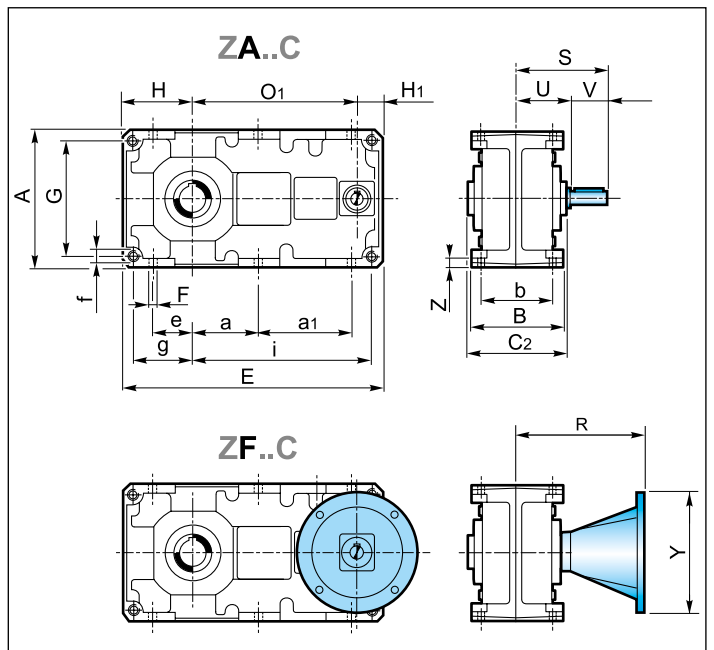
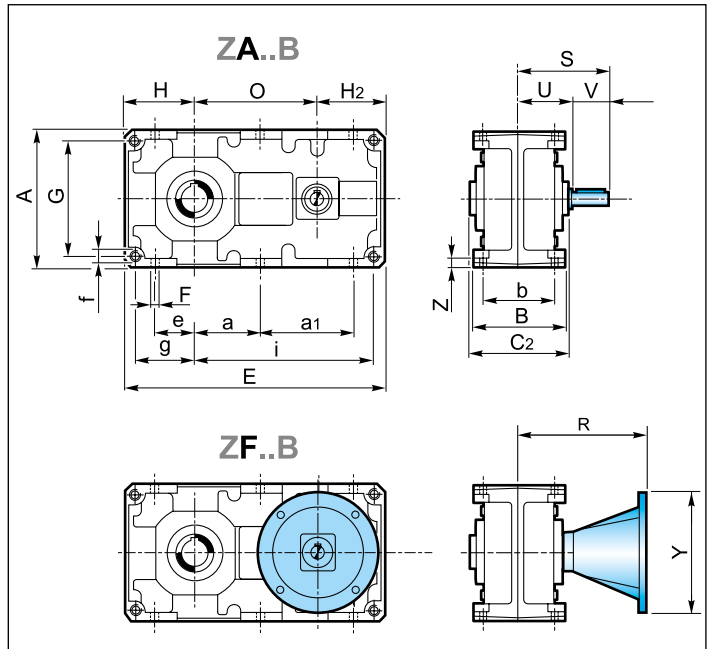
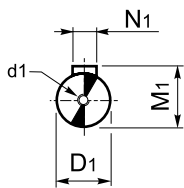

ZA...A						
	71	90	112	140	180	225
D1 h6	19	24	28	38	48	60
d1	M8	M8	M8	M10	M12	M16
M1	21.5	27	31	41	51.5	64
N1	6	8	8	10	14	18
ZA...B						
	80	100	125	160	180	200
D1 h6	19	24	28	38	38	48
d1	M8	M8	M8	M10	M10	M12
M1	21.5	27	31	41	41	51.5
N1	6	8	8	10	10	14
ZA...C						
	80	100	125	160	180	200
D1 h6	14	19	24	28	28	38
d1	M6	M8	M8	M8	M8	M10
M1	16	21.5	27	31	31	41
N1	5	6	8	8	8	10

ZA...A														
	71	90	112	140	180	225								
C2	115	130	155	180	220	300								
D2 H7	24	28	32	30	35	42	40	45	55	50	70	60	100	90
M2	27.3	31.3	35.3	33.3	38.3	45.3	43.3	48.8	59.3	53.8	74.9	64.4	106.4	95.4
N2	8	8	10	8	10	12	12	14	16	14	20	18	28	25
Z2	—	8.7	8.7	8.4	11	11	11	11.9	15.4	15.9	20	-	-	-
ZA...B - ZF...B - ZA...C - ZF...C														
	80	100	125	160	180	200								
C2	130	155	180	220	260	300								
D2 H7	32	30	35	42	40	45	55	50	70	60	90	80	100	90
M2	35.3	33.3	38.3	45.3	43.3	48.8	59.3	53.8	74.9	64.4	95.4	85.4	106.4	95.4
N2	10	8	10	12	12	14	16	14	20	18	25	22	28	25
Z2	8.7	8.7	8.4	11	11	11	11.9	15.4	15.9	18.9	18.9	20	-	-

Albero uscita cavo
Hollow output shaft
Abtriebshohlwelle

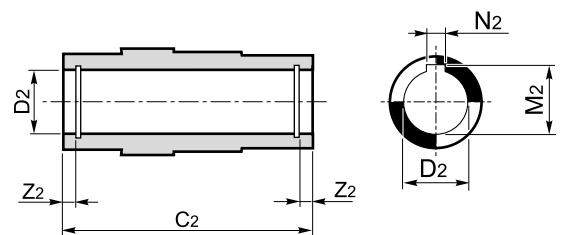

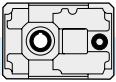

3.8 Dimensioni

3.8 Dimensions

3.8 Abmessungen

	ZA...A						ZA...B - ZF...B - ZA...C - ZF...C																			
	71	90	112	140	180	225	80	100	125	160	180	200														
A	142	180	224	280	360	450	160	200	250	320	360	400														
a	102	134	166	209	272.5	344	82	102	127	162.5	185	204														
a1	—						106	134	169	217	207	277.5														
B	112	127	150	175	215	290	127	150	175	215	255	290														
b	90	104	125	145	180	240	104	125	145	180	210	240														
C2	115	130	155	180	220	300	130	155	180	220	260	300														
D2 H7	24	28	32	30	35	42	40	45	55	50	70	60	100	32	30	35	42	40	45	55	50	70	60	90	80	100
E	206	262	326	407	522.5	654	306	384	479	609.5	652	766.5														
e	38	52	64	82	110	140	42	52	67	90	100	115														
F	9	11	13	15	17	21	11	13	15	17	19	21														
f	M8x13	M10x16	M12x19	M14x21	M16x25	M18x30	M10x16	M12x19	M14x22	M16x25	M18x35	M18x30														
G	122	155	194	244	320	400	135	170	214	280	310	350														
g	61	77.5	97	122	160	200	67.5	85	107	140	155	175														
H	71	90	112	140	180	225	80	100	125	160	180	200														
H1	—						35	36	43	58	58	73														
H2	—						80	100	125	160	160	200														
i	125	159.5	199	249	322.5	404	213.5	269	336	429.5	447	541.5														
O	64	82	102	127	162.5	204	146	184	229	289.5	312	366.5														
O1	—						191	248	311	391.5	414	493.5														
Z	9	11	13	15	17	25	11	13	15	17	22	25														

	ZA...A						ZA...B						ZA...C					
	71	90	112	140	180	225	80	100	125	160	180	200	80	100	125	160	180	200
D1 h6	19	24	28	38	48	60	19	24	28	38	38	48	14	19	24	28	28	38
S	105	127.5	150	190	230	260	105	127.5	150	190	210	230	95	117.5	140	170	190	230
U	65	77.5	90	110	150	150	65	77.5	90	110	130	150	65	77.5	90	110	130	150
V	40	50	60	80	80	110	40	50	60	80	80	80	30	40	50	60	60	80
kg	11.5	18	30.5	52	104	210	18	34	62	114	165	250	20	38	68	125	180	275

	ZF...B																		
	80			100			125			160			180			200			
IEC	71	80/90	71	80/90	100/112	80/90	100/112	132	90	100/112	132	160/180	80/90	100/112	132	160/180	132	160/180	200
Y	160	200	160	200	250	200	250	300	200	250	300	350	200	250	300	350	300	350	400
R	151	172	162	182	192	205	215	236	245	255	276	306	266	276	297	327	316	346	348
kg	21		39			72			131			185			280				

	ZF...C																		
	80			100			125			160			180			200			
IEC	63	71	80/90	71	80/90	71	80/90	100/112	80/90	100/112	132	80/90	100/112	132	100/112	132	100/112	132	160/180
Y	140	160	200	160	200	160	200	250	200	250	300	200	250	300	250	300	250	300	350
R	132	139	160	152	173	176	197	207	230	240	261	245	255	276	295	316	316	348	348
kg	23			43			78			142			200			305			