

2.8 Dati tecnici

2.8 Technical data

2.8 Technische Daten

EP 155																		Stadi Steps Stufenzahl	
Stadi Steps Stufenzahl	1					2													
i	3	4	5	7	10	9	12	15	16	20	25	28	35	40	50	70	100	1	2
T_{2N}	240	320	380	300	220	320	400	500	500	500	500	500	500	500	500	350	250	n_{1nom}	3000
T_{2A}	420	540	600	480	400	480	600	750	750	750	750	750	750	750	750	560	460	n_{1max}	4000
T_{2S}	880	1140	1260	1000	850	1000	1250	1500	1500	1500	1500	1500	1500	1500	1500	1120	920	LpA	< 70
J	Vedi pag. 33 / See page 33 / Siehe auf Seite 33																	Lh	20000
R_t	60				50	60											50	F_{R2} (AA)	6500
																		F_{R2} (TT)	5300
R_d	0.96					0.93												F_{A2} (AA)	3250
																		F_{A2} (TT)	2650
Kg	10.9					15.7												α_{max}	8' 10'

2.9 Dimensioni

2.9 Dimensions

2.9 Abmessungen

Dimensioni generali e uscite / General and output dimensions / General-und Abtriebsabmessungen

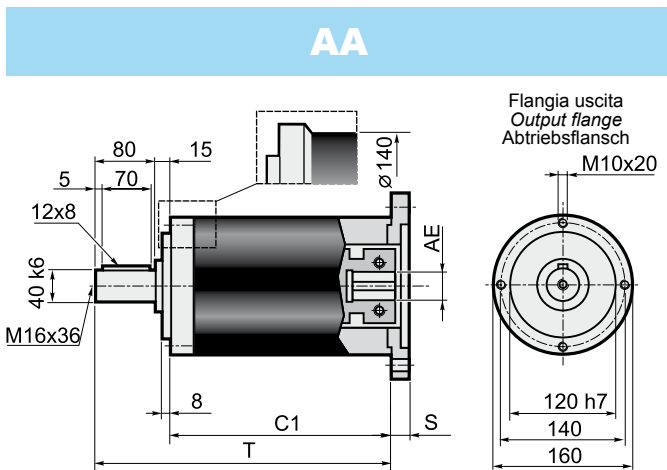

Stadi / Steps / Stufenzahl	1	2	AE= 15.87-16-19-22-24
C1	156	197.5	
T	251	292.5	
Stadi / Steps / Stufenzahl	1	2	AE= 28-32-35-38
C1	181	222.5	
T	276	317.5	

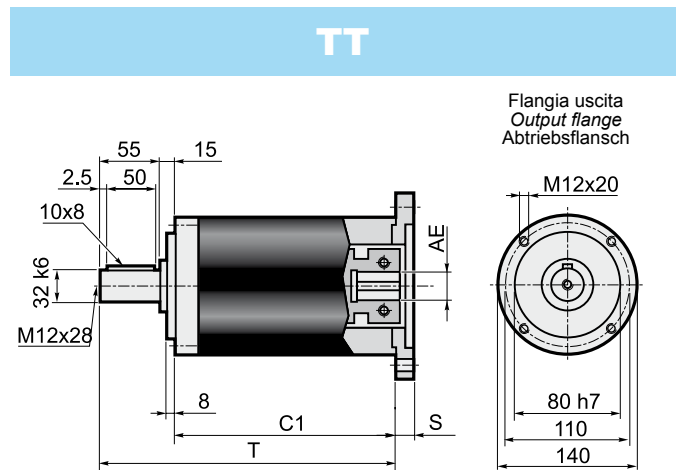

Stadi / Steps / Stufenzahl	1	2	AE= 15.87-16-19-22-24
C1	156	197.5	
T	226	267.5	
Stadi / Steps / Stufenzahl	1	2	AE= 28-32-35-38
C1	181	222.5	
T	251	292.5	

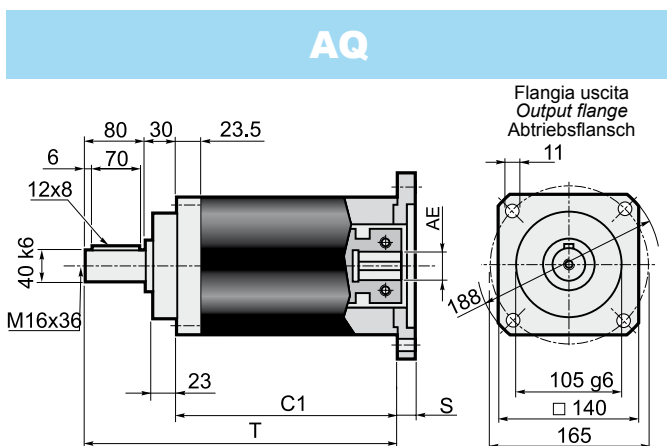

Stadi / Steps / Stufenzahl	1	2	AE= 15.87-16-19-22-24
C1	141	182.5	
T	251	292.5	
Stadi / Steps / Stufenzahl	1	2	AE= 28-32-35-38
C1	166	207.5	
T	276	317.5	

Dimensioni entrate / Input dimensions / Antriebsabmessungen

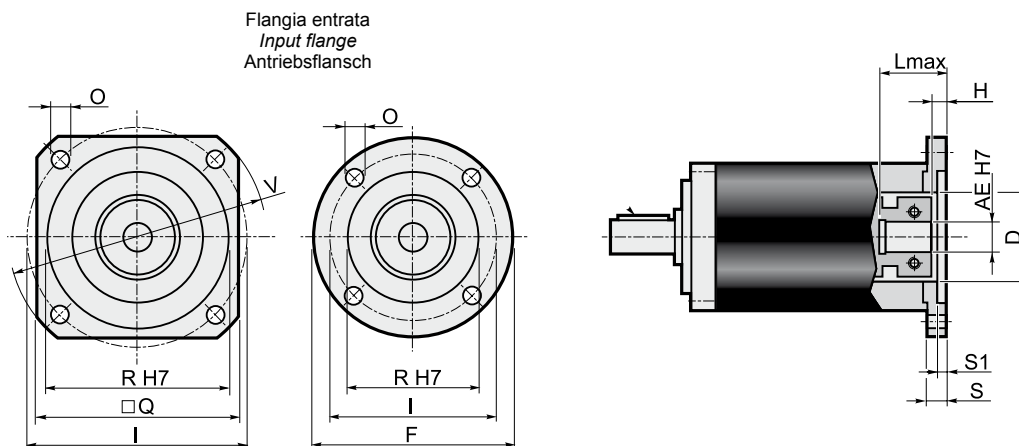

	Flange entrata / Input flange / Antriebsflansch									Albero entrata / Input shaft / Antriebswelle																	
										AE																	
										15.87		16		19		22		24		28		32		35		38	
F	Q	V	I	R (H7)	O	S	S1	D	L _{max}	H	L _{max}	H	L _{max}	H	L _{max}	H	L _{max}	H	L _{max}	H	L _{max}	H	L _{max}	H			
P01*	140	=	=	125.72	55.52	6.5	15	4	55.52	57.8	6.8	57.8	6.8	42.8	6.8	57.8	6.8	57.8	6.8	82.8	7.3	82.8	7.3	82.8	7.3	82.8	7.3
P02*	140	=	=	100	80	6.5	15	4	70	57.8	6.8	57.8	6.8	42.8	6.8	57.8	6.8	57.8	6.8	82.8	7.3	82.8	7.3	82.8	7.3	82.8	7.3
P03*	140	=	=	115	95	8.5	15	4.5	70	57.8	6.8	57.8	6.8	42.8	6.8	57.8	6.8	57.8	6.8	82.8	7.3	82.8	7.3	82.8	7.3	82.8	7.3
P04*	=	140	160	130	110	8.5	15	4.5	70	57.8	6.8	57.8	6.8	42.8	6.8	57.8	6.8	57.8	6.8	82.8	7.3	82.8	7.3	82.8	7.3	82.8	7.3
P05	=	142	190	165	130	11	15	4.5	70	57.8	6.8	57.8	6.8	42.8	6.8	57.8	6.8	57.8	6.8	82.8	7.3	82.8	7.3	82.8	7.3	82.8	7.3
P06	=	190	250	215	180	13	15	4.5	70	57.8	6.8	57.8	6.8	42.8	6.8	57.8	6.8	57.8	6.8	82.8	7.3	82.8	7.3	82.8	7.3	82.8	7.3
P07	=	250	300	265	230	13	15	4.5	70	57.8	6.8	57.8	6.8	42.8	6.8	57.8	6.8	57.8	6.8	82.8	7.3	82.8	7.3	82.8	7.3	82.8	7.3
P08	=	130	165	145	110	M 8	18	7	70	60.8	9.8	60.8	9.8	45.8	9.8	60.8	9.8	60.8	9.8	85.8	10.3	85.8	10.3	85.8	10.3	85.8	10.3
P09	=	180	230	200	114.3	13.5	22	11	70	64.8	13.8	64.8	13.8	49.8	13.8	64.8	13.8	64.8	13.8	89.8	14.3	89.8	14.3	89.8	14.3	89.8	14.3
P10	=	115	150	130	95	M 8	15	4.5	70	57.8	6.8	57.8	6.8	42.8	6.8	57.8	6.8	57.8	6.8	82.8	7.3	82.8	7.3	82.8	7.3	82.8	7.3
P11	=	180	230	198	155	13.5	22	7	120x11	64.8	13.8	64.8	13.8	49.8	13.8	64.8	13.8	64.8	13.8	89.8	14.3	89.8	14.3	89.8	14.3	89.8	14.3
P12	=	220	270	235	200	13.5	15	5	70	57.8	6.8	57.8	6.8	42.8	6.8	57.8	6.8	57.8	6.8	82.8	7.3	82.8	7.3	82.8	7.3	82.8	7.3
P13	=	190	250	215	130	13	15	4.5	70	57.8	6.8	57.8	6.8	42.8	6.8	57.8	6.8	57.8	6.8	82.8	7.3	82.8	7.3	82.8	7.3	82.8	7.3
P14	=	142	190	165	110	11	15	4.5	70	57.8	6.8	57.8	6.8	42.8	6.8	57.8	6.8	57.8	6.8	82.8	7.3	82.8	7.3	82.8	7.3	82.8	7.3
P15*	150	=	=	90	70	6.5	15	4	70	57.8	6.8	57.8	6.8	42.8	6.8	57.8	6.8	57.8	6.8	82.8	7.3	82.8	7.3	82.8	7.3	82.8	7.3
P16	=	146	200	177.8	114.3	10.5	15	3.5	70	57.8	6.8	57.8	6.8	42.8	6.8	57.8	6.8	57.8	6.8	82.8	7.3	82.8	7.3	82.8	7.3	82.8	7.3
P17	=	130	165	145	110	M 8	28	7	70	-	-	-	-	70.8	19.8	-	-	-	-	-	-	-	-	-	-	-	-
P18	140	=	=	100	80	M 6	22	6	70	64.8	13.8	64.8	13.8	49.8	13.8	64.8	13.8	64.8	13.8	89.8	14.3	89.8	14.3	89.8	14.3	89.8	14.3

* Per assemblare il motore è necessario smontare la flangia dal riduttore (vedere schema di montaggio 2 a pag. 45).

* Before the mounting of the motor it is necessary to remove the flange from the gearbox (see structural arrangement 2 at the top of the page 45).

* Vor dem Einbauen des Motors soll die Getriebeflangsch abmontiert werden (siehe Bauanleitung 2 auf Seite 45).