

### CMI...B - I...FP

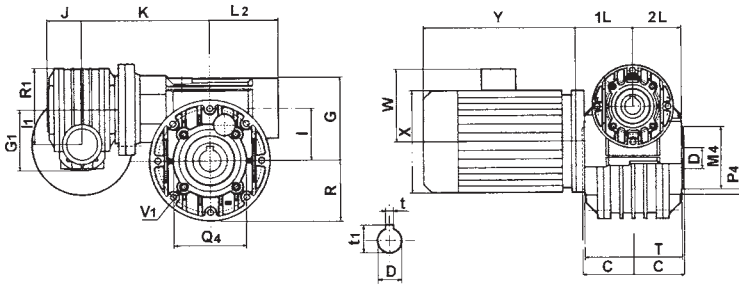

ESECUZIONE / EXECUTION / BAUFORM  
EXÉCUTION / MODELO / EXECUÇÃO

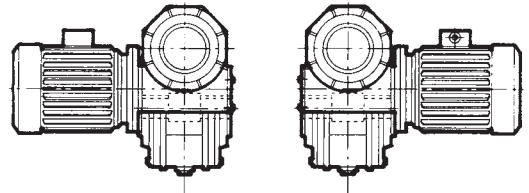

BPL  
STANDARD

BPR

### CMI...A - I...FP

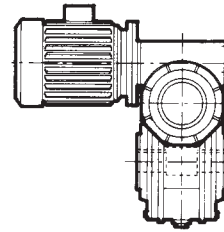
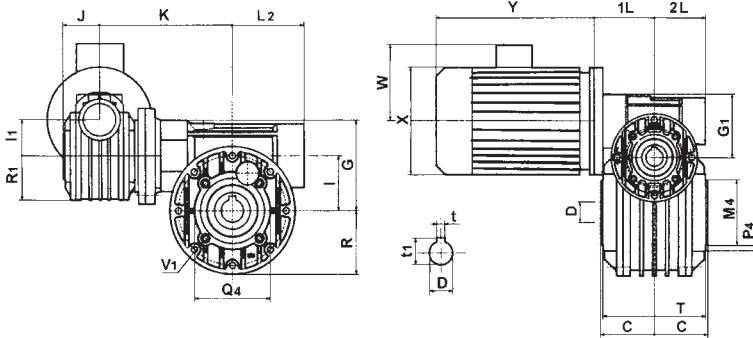

APL  
STANDARD

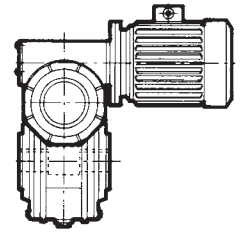

APR

### CMI...V - I...FP

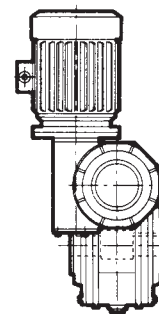
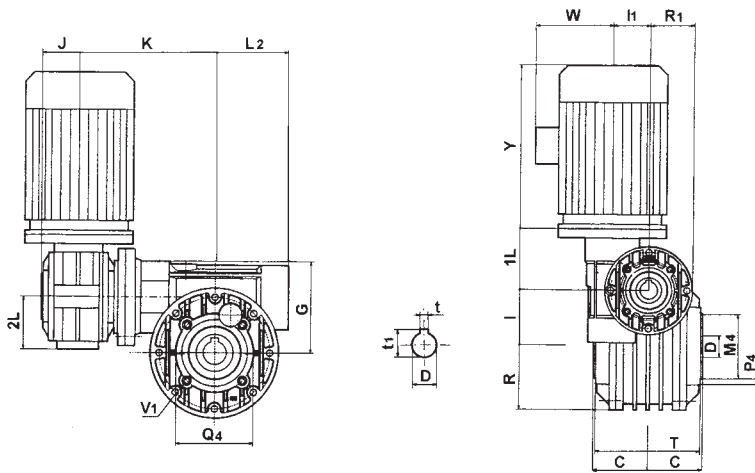

VPL  
STANDARD

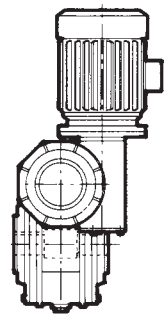

VPR

	M <sub>1</sub> G6	M <sub>4</sub> G6	N <sub>1</sub>	O <sub>1</sub>	P <sub>1</sub>	P <sub>4</sub>	Q <sub>1</sub>	Q <sub>4</sub>	S <sub>1</sub>	V <sub>1</sub>	V <sub>4</sub>	G	I	I <sub>1</sub>	1L	L <sub>2</sub>	2L	R	R <sub>1</sub>	T	J	K	C	D H7	t	t <sub>1</sub>
CI 40 I 40	95	50	11	82	140	96	115	65	4	9	M6	66	40	40	71	57	59	48	59	77	41	110,5	41	19	6	21,8
CI 40 I 50	110	60	11	92	160	88	131	75	4	10	M6	80	50	40	71	67	59	56	59	93	41	131,7	49	24	8	27,3
CI 40 I 60	130	70	12	102	200	105	165	85	4	11	M8	94	60	40	71	80	59	75	59	104	41	147,7	60	25	8	28,3
CI 40 I 70	130	80	12	111,5	200	115	165	100	4	44	M8	113	70	40	71	86	59	81	59	114	41	149,7	60,5	28	8	31,3
CI 50 I 70	130	80	12	111,5	200	115	165	100	5	11	M8	113	70	40	85	86	69	81	65	114	49	157,0	60,5	28	8	31,3