

2.11 Accessori

2.11 Accessories

2.11 Zubehör

Albero lento

Output shaft

Abtriebswelle

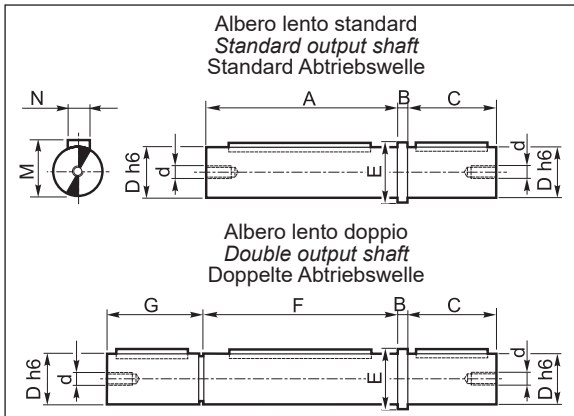

	T											
	56B 56C	63B 63C	75B 75C	71B	90B 80C	112B 100C	140B 125C	180B 160C	200B 180C	225B 200C		
A	100	120	123	114	129	129	154	154	179	219	259	298
B	5	5	6	5	6	6	8	8	10	12	15	15
C	40	45	60	50	60	60	80	80	100	125	140	180
D_{h6}	20	25	35	24	32	35	42	45	55	70	90	100
d	M8	M8	M10	M8	M8	M8	M10	M10	M10	M12	M16	M18
E	26	32	43	30	40	43	50	53	65	80	110	118
F	100	120	125	115	130	—	155	—	180	220	260	300
G	41	46	60	49	59	—	79	—	99	124	141	178
M	22.5	28	38	27	35	38	45	48.5	59	74.5	95	106
N	6	8	10	8	10	10	12	14	16	20	25	28

Materiale albero lento: **C45**
Output shaft material: **C45**
Material der Abtriebswelle: **C45**

**Kit fissaggio e smontaggio
riduttori con albero lento cavo
(escluso T 56, 63, 71 e 75)**

**Kit for the mounting and dismounting
of the gearboxes with hollow output
shaft (except T 56, 63, 71 and 75)**

**Kit für Montage und Ausbau der
Getriebe mit Abtriebshohlwelle
(außer dass T 56, 63, 71 und 75)**

	T												
	90B 80C			112B 100C			140B 125C		180B 160C		200B 180C		225B 200C
C2	130			155			180		220		260		300
D2	32	30	35	42	40	45	55	50	70	60	90	80	100
H	8	7	6.5	10	8		9		12		16	15.5	17
d1	—			—			M10		M12		M16		M18
d2	—			—			M8		M10		M12		M16
d3	M8			M8			—		—		—		—
d4	M12			M12			—		—		—		—
Z2	8.7		8.4	10.7			11.9		15.4	15.9	18.9	19.4	16.9
Lmax	111	112		131	133		156		189		221		262
Lmin	106	107		126	128		149		182		211		252

